



Innovation  
that excites

370Z®



## NISSAN INTELLIGENT MOBILITY

Nissan Intelligent Mobility guides everything we do. We're using new technologies to transform cars from mere driving machines into partners. Together, the journey is more confident, connected, and exciting. Whether it's cars that share the task of driving with you, or highways that charge your EV as you go along, it's all in the very near future. And it's a future already taking shape in the Nissan you drive today.

Nissan. Innovation that excites.  
nissan.ph

 NissanPhilippinesInc

Nissan Intelligent Choice  
cpo.nissanph.com

**24/7** CUSTOMER  
ASSISTANCE  
CENTER **8403-6593**  
**0927-600-9557**

Photo may vary from actual unit.

Every drive is something special. The battle cry of a legendary 332 Ps VQ V6 paired with the world's first rev-matching manual transmission. The relentless cornering grip of a dynamically balanced chassis talking to you through a driver-focused cockpit. The Nissan 370Z. This is tech that moves you.



Nissan 370Z® Premium shown in Vibrant Red

Photo may vary from actual unit.



# 3.7

LITER

## V6

# 332

PS

# 363

Nm



### PERFECT BALANCE OF CONFIDENCE AND CONTROL

Designed to conquer corners, the Nissan 370Z starts with a low center of gravity and a short wheelbase for quick response. Bring them all together with an enthusiast's wish list of high-performance componentry, and you'll find pure joy as the 370Z elevates handling science into pure performance art.



### SYNCHROREV MATCH® TECHNOLOGY

A world's first in any production car, SynchroRev Match monitors the 6-speed manual's clutch, shift lever, and vehicle speed. As you shift to a lower gear, the system "blips" the throttle to the ideal engine rpm for a supremely smooth downshift.

### 55/45 WEIGHT DISTRIBUTION

Instead of the traditional 50/50 split, Nissan engineers determined that a 55 front/45 rear static ratio is ideal for the Z. At the precise moment the driver accelerates out of a corner's apex, the weight distribution shifts rearward and becomes an approximate 50/50 balance, translating into enhanced tire contact for better acceleration, quicker turns, and a handling feel that's uniquely Nissan Z.



▲  
55

▲  
45

### A DRIVER'S AUTOMATIC TRANSMISSION

This available 7-speed automatic gives you a wide spread of gearing and improved fuel efficiency. Driver-selectable modes let you custom-tailor your driving experience.



### 6-SPEED MANUAL TRANSMISSION

No detail was overlooked. The 6-speed manual's shift features thicker front and rear padding for comfort, while the sides feature less padding for better feel and precision when navigating through the gears.





**1** 19-INCH ALLOY WHEELS BY RAYS®

**2** LED DAYTIME RUNNING LIGHTS

**3** BOOMERANG HEADLIGHTS

**4** DUAL EXHAUST TIPS

**5** REAR SPOILER

**6** LEGENDARY NISSAN Z LOGO



## THE DRIVER, FIRST AND FOREMOST



Gauges that move with the steering column, ensuring a clear view. A driver's seat with special cutaways that give arms and legs room to move. From the moment you get in, you can tell – the Z interior has been custom-tailored to give you the drive of your life.



### PUSH BUTTON IGNITION

Adrenaline on Tap. Nissan Intelligent Key® lets you start your Z with the push of the button. Press it again, and the engine turns off.



### NISSAN INTELLIGENT KEY

With your Nissan Intelligent Key in your pocket or purse, you can unlock the door or hatchback just by pressing a button on the vehicle.



### BOSE® PREMIUM AUDIO SYSTEM

Guaranteed to amplify your experience. The Z's custom-engineered Bose® Premium Audio System features 8 top-of-the-line speakers.



### 1 INFORMATION LAYER

Gauges are easily read at a glance. The main instrument cluster moves with the steering column, so the steering wheel won't obstruct your view.

### 2 OPERATION LAYER

Controls are within reach, and shaped for easy identification to help minimize time looking away.

### 3 HOLDING LAYER

Supportive bolstered sport seats help hold you in place. There's even padding on the transmission tunnel to help brace yourself in turns.



What happens when the inspired engineers at NISMO are let loose on the 370Z? You get 344 horsepower surrounded by a NISMO-tuned suspension and a driver-focused interior, all wrapped in a jaw-dropping NISMO-designed aerodynamic body. Obsessive? Perhaps. Extraordinary? Most definitely.



**Competition-tuned handling. Competition-inspired design.** Serious grip starts with specially tuned springs, shocks, and stabilizer bars designed to satisfy the most demanding enthusiast. Extra braces on the front strut tower bar and special vibration dampers on the front body frame rail and rear subframe are added for impressive overall body rigidity and the feel of a controlled ride. A true work of performance art, the 370Z NISMO entices the eye of its 19" RAYS forged alloy wheels, high downforce body, aggressive front and rear fascia, and rear diffuser.



## CHASSIS ENHANCEMENT

Special body dampers mounted up front on the frame rail and in back under the cargo area help dampen body vibrations for better control and precise steering. Braces on the front strut aid in improving overall body rigidity.

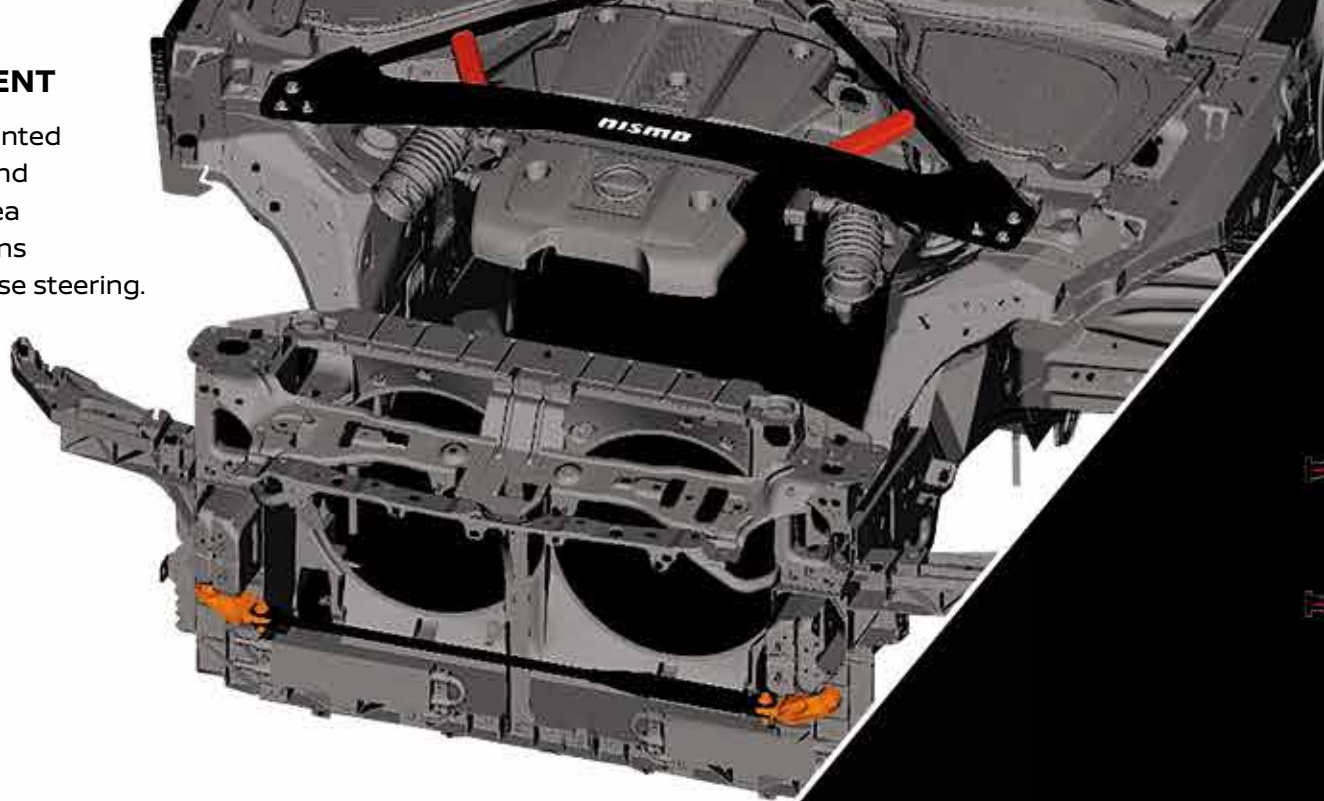

## H-PIPE FREE-FLOW DUAL EXHAUST

A free-flow dual exhaust combined with an H-pipe configuration reduces back pressure by up to 30%. The result: responsive upper-end power for an exhilarating redline rush and an exhaust note that's pure performance.

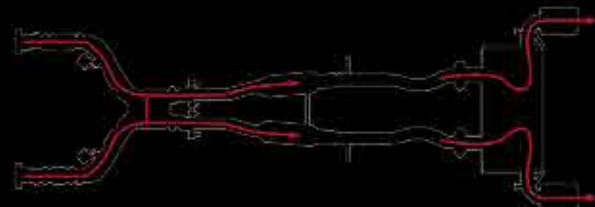

## TUNED SUSPENSION

Poised to devour a day at the track, the aggressive, competition-tuned independent suspension will satisfy even the most demanding drivers. Up front and in back, we've added stiffer springs that decrease travel and help limit body roll.



## WHEELS BY RAYS

Connecting the tires to the chassis are staggered-width 19" x 9.5" front and 19" x 10.5" rear Rays® Forged Alloy wheels with an aggressive NISMO two-tone finish.



## AERODYNAMICS AND DOWNFORCE

Decades of motorsport experience and years of wind-tunnel tweaking helped NISMO engineers meet the need for serious downforce without compromising its iconic lines and low drag coefficient.



## RECARO® ALCANTARA®

These leather-appointed Recaro® performance seats were built to fit you like a glove. Contrasting red inserts in grippy Alcantara®, integrated headrests, firm bolsters, and an embossed Recaro® logo and embroidered NISMO logo make them as stunning as they are supportive.



# 370Z SPECIFICATIONS AND FEATURES

VARIANT		PREMIUM	NISMO
<b>ENGINE / TRANSMISSION</b>			
Engine Type	3.7-liter, DOHC, 24-valve V6 (VQ37)		
Bore x Stroke	mm	95.5 x 86	
Maximum Power	ps/rpm	332 / 7,000	344 / 7,400
Maximum Torque	Nm/rpm	363 / 5,200	371 / 5,200
Required Fuel	95 Octane		
Fuel Tank Capacity	liters	72	

DRIVETRAIN			
Drive System		Rear Wheel Drive	
Transmission	Type	6-Speed Manual / 7-Speed Automatic with Manual Mode	7-Speed Automatic with Manual Mode
	Paddle Shift	With (For Automatic)	With (NISMO Design Black Magnesium)
	Downshift Rev-Matching	With	
Limited Slip Differential		With	
Carbon-Fiber Composite Driveshaft		With	

SUSPENSION / CHASSIS / STEERING			
Suspension	Type	Standard Type	NISMO-Tuned with Increased Spring and Damping Rates
	Front	Double-wishbone Aluminum Alloy with Aluminum Subframe	
	Rear	Multi-link Aluminum Alloy	
Stabilizer Bars		With	With (NISMO)
Brakes	Type	Nissan Sport Brakes	
	Front	4-Piston 14" Ventilated Disc	
	Rear	2-Piston 13.8" Ventilated Disc	
Wheels	Front	19" x 9" Forged Alloy Wheels by RAYS®	19" x 9.5" NISMO Forged Alloy Wheels by RAYS®
	Rear	19" x 10" Forged Alloy Wheels by RAYS®	19" x 10.5" NISMO Forged Alloy Wheels by RAYS®
Tires	Front	245 / 40 R 19	
	Rear	275 / 35 R 19	285 / 35 R 19
Steering Type		Vehicle Speed-Sensitive Hydraulic Rack & Pinion	
Min. Turning Radius		m	5.2

DIMENSIONS / WEIGHT			
Dimensions (L x W x H)	mm	4,265 x 1,845 x 1,315	4,330 x 1,870 x 1,315
Wheelbase	mm	2,550	
Ground Clearance	mm	125	
Trunk Capacity	liters	235	
Seating Capacity	persons	2	
Curb Weight	kg	1,582 / 1,594	1,609

EXTERIOR			
Headlamps		Bi-Xenon HID Projector Type (Auto Leveling, Auto On/Off with Washer)	
Daytime Running Lamps (DRL)		With (LED)	
Tail Lamps		LED Type	
Side Turn Lamps		Integrated in Emblem (LED)	
Rear Fog Lamp		With	
Door Mirror	Power Adjust and Power Folding (Body Color)		Power Adjust and Power Folding (NISMO Design)
Door Handle		Aluminum Door Handles with i-Key Switch	
Front Bumper	Standard Type with Spoiler		NISMO Design
Rear Bumper	Standard Type		NISMO Design
Rear Spoiler	With		With (NISMO Design)
Side Skirt	With		With (NISMO Design)
Exhaust	Dual Exhaust		NISMO Type Dual Exhaust
Wiper	Front	Variable Intermittent	

VARIANT	PREMIUM	NISMO	
<b>INTERIOR</b>			
Seats	Type	<b>Sport Seats</b> (Power Slide and Recline)	<b>NISMO Recaro Seats</b> (Manual Slide and Recline)
	Height Adjuster	Driver Side with Lumbar Adjustment	Driver Side
	Material	Leather	Leather with Alcantara Insert
Steering Wheel	Type	3-Spoke Leather Wrapped	NISMO 3-Spoke Leather and Alcantara-Wrapped
	Controls	Audio, Hands-Free Telephone, Cruise Control	
	Adjustment	Manual Tilt	
Shift Boot		With Silver Trim	with NISMO Badge
Pedals		Aluminum Sport Pedals	
Rear View Mirror		Manual Day/Night	
Sun Visor		Driver and Front Passenger with Vanity Mirror and Illumination	
Meter		Standard with Multi-Information Display	NISMO-Design with Multi-Information Display
Lamps		Map Lamp and Cargo Area	

FUNCTION		
Keyless Entry System		With (Intelligent Key)
Engine Push Start-Stop System		With
Power Windows		One-Touch Auto-Up/Down with Anti-Pinch
Power Door Locks		With
Air Conditioning System		Automatic Type
Cruise Control		With
Audio	Type	Dealer Option
	Speakers	BOSE® 8-Speaker Audio System (including Subwoofer)
Active Noise Cancellation		With
Active Sound Enhancement		With

SAFETY / SECURITY		
SRS Airbags		Driver, Passenger, Side and Side Curtain
Anti-Lock Braking System (ABS)		With Brake Assist (BA)
Vehicle Dynamic Control (VDC)		With
Traction Control System (TCS)		With
High Mount Stop Lamp		With (LED)
Seatbelts	Front	3 Point ELR with Pre-tensioner and Load Limiter
Anti-Theft System		Alarm with Engine Immobilizer

Nissan Philippines, Inc. reserves the right to alter, delete, or enhance features and specifications without prior notice, depending on market requirements.

## CHOOSE YOUR COLOR

